

SIDE-POWER

Thruster systems



Product Specifications SP 30 Si



Thrusters are not only helpful for large yachts, typically a light weight boat with a single outboard or stern-drive are even more difficult and stressful to handle in tight spots than larger yachts that are less effected by the wind. With its outstanding performance, excellent energy efficiency and very compact installation size, the **SP 30 Si** includes all the important and unique **Side-Power** features and qualities - **why settle for less.**

Easy and safe to install:

- Easy access terminals for easy, fast and safe fitting of main battery cables (as opposed to having to fit directly onto "crowded" solenoid studs. Own by overheat sensor in motor.
- Plug and go control wiring.
- Fast, easy and safe fitting of propeller with lock-nut as opposed to difficult and unreliable set-screw fastening.
- Self aligning drilling template available for OEM customers.
- All sharp edges removed to avoid installers getting injuries.



Description

Typical boat size 20 - 28 foot (see back page for more info)
 Tunnel inside diameter 125 mm / 4,92"
 Propulsion system Single 4bl composite
 Available for DC system 12 V
 Weight 9,5 kg / 21 lbs.

Gearleg:

- Seawater resistant bronze, CNC machined in one process to ensure 100% correct tolerances, angles and measurements.
- Oil filled with header tank and breathing to ensure long lifetime and no contamination of oil.
- Marine grade seals with protective lip and mechanically protected by special propeller hub design.
- Hardened and ground precision spiro-conical gears.
- Propeller shaft with double ball bearings fitted in correct tolerances.
- Driveshaft with ball bearing and special sleeve bearing in correct tolerances.
- Connection between motor and driveshaft by shear-pin, changable from inside the boat.
- Symmetrical 4 bladed composite kaplan propeller.
- Zinc anode protection directly on gearleg, easy to access and change.

Performance and specifications at one tunnel diameter depth * :

	at 10,5V	at 12,0V
Thrust	30 kg / 66 lbs.	38 kg / 88 lbs.
Output power	1,6 kW / 2,1 Hp	2,0 kW / 2,7 Hp
Average current draw	180 A	250 A
Continous run time (20°C)	3 min.	2 min 40 sec
Approx. long term run time	12% of time	10% of time
Min. battery CCA rating	200 by DIN / 370 by BCI/SAE	
Side-Power fuse size:	ANL150	

Safety features on thruster (see separate sheet for control panels):

- Forced shut-down by overheat sensor in motor
- All internal leads with extra insulation of webbed silicon increase resistance to heat and mechanical wear. Connectors have positive locking so that you have to pull by the insulator to release, can not be pulled off by the wires or loosen by themselves. Self extinguishing solenoid cover.
- IPC Standard electronic control box for protection against:
 - direct drive direction change
 - unique, patented protection of solenoid from extra wear and damages in low voltage situations for example caused by drained or damaged batteries as well as "auto-stop" without the need for the skipper to shut down the main switch immediately to stop the thruster in case of a solenoid lock-in **
 - auto-stop if control signal is continuous for more than 3 minutes to protect against potential short circuit in control cables.

Notes !

* Actual performances, current consumption etc. will vary for each installation depending on many factors. Specifications here given at one tunnel diameter depth and with voltage at thruster as shown. If you install deeper the thrust will be more as well as the current consumption, and the running time will be reduced. Electromotors power and efficiency tolerances are +/- 6%.

** New patented safety features in the thruster controlbox will be available in 2005 model year units.

SIDE-POWER

Thruster systems



Product Specifications SP 30 Si

Installation planning

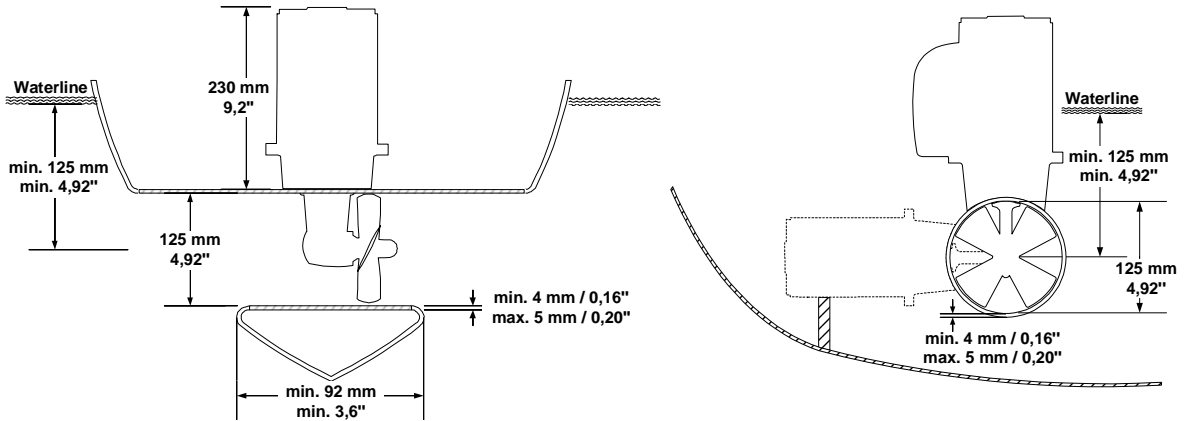

Table for selection of main cable, battery, fuse and main-switch sizes.			up to 7m total + & -		8 - 11m total + & -		12 - 15m total + & -		16 - 19m total + & -		20 - 23m total + & -	
Model	Voltage	Current draw	Min. Cable dimension	Min. Battery CCA by DIN	Min. Cable dimension	Min. Battery CCA by Din	Min. Cable dimension	Min. Battery CCA by DIN	Min. Cable dimension	Min. Battery CCA by Din	Min. Cable dimension	Min. Battery CCA by DIN
SP 30 Si	12 V	195 A	25 mm ² AWG 2	200 CCA Din	35 mm ² AWG 1	200 CCA Din	50 mm ² AWG 0	200 CCA Din	60 mm ² AWG 0	200 CCA din	70 mm ² AWG 00	225 CCA din

Typical boat sizes:

SP30Si push bow against a direct sidewind of approximately:

SeaRay 245 Weekender - 23,7 knots.



SeaRay 260 Sundancer - 21,2 knots.



Aquador 23 WA - 22,7 knots.



Aquador 23 Cabin - 22,8 knots.



Sleipner Motor AS
P.O. Box 519
N-1612 Fredrikstad
Norway

Tel: +47 69 30 00 60
Fax: +47 69 30 00 70

www.side-power.com
sidepower@sleipner.no

