

SIDE-POWER

Thruster systems

Product Specifications SP 55 Si



Thrusters are not only helpful for large yachts, typically a light weight boat with a single outboard or stern-drive are even more difficult and stressful to handle in tight spots than larger yachts that are less effected by the wind. With its outstanding energy efficiency and unrivalled reliability, the **SP 55 Si** is the "classic" and best selling thruster in the Sidepower series and includes all the important and unique **Side-Power** features and qualities - **why settle for less.**

Easy and safe to install:

- Easy access terminals for easy, fast and safe fitting of main battery cables (as opposed to having to fit directly onto "crowded" solenoid studs. Own by overheat sensor in motor.
- Plug and go control wiring.
- Fast, easy and safe fitting of propeller with lock-nut as opposed to difficult and un-reliable set-screw fastening.
- Self aligning drilling template available for OEM customers.
- All sharp edges removed to avoid installers getting injuries.



Description

Typical boat size 28 - 38 foot (see back for more info)
Tunnel inside diameter 185mm/7,3" (see back for more measurements)
Propulsion system Single 4bl composite
Available for DCsystem 12V or 24V
Weight 16 kg/35 lbs.

Gearleg:

- Seawater resistant bronze, CNC machined in one process to ensure 100% correct tolerances, angles and measurements.
- Oil filled with header tank and breathing to ensure long lifetime and no contamination of oil.
- Marine grade seals with protective lip and mechanically protected by special propeller hub design.
- Hardened and ground precision spiro-conical gears.
- Propeller shaft with double ball bearings fitted in correct tolerances.
- Driveshaft with ball bearing and special sleeve bearing in correct tolerances.
- Connection between motor and driveshaft by shear-pin, changable from inside the boat.
- Symmetrical 4 bladed composite kaplan propeller.
- Zinc anode protection directly on gearleg, easy to access and change.

Performance and specifications at one tunnel diameter depth * :

| | at 10,5V / 21V | at 12,0V / 24V |
|----------------------------|------------------------------|--------------------|
| Thrust | 57 kg / 125 lbs. | < 68 kg / 150 lbs. |
| Output power | 3,1 kW / 4 Hp | < 3,6 kW / 4,7 Hp |
| Average current draw | 320 A / 150A | < 355 A / 175A |
| Continous run time (20°C) | 3 min. | > 2 min 40 sec |
| Approx. long term run time | 12% of time | 8% of time |
| Min. battery CCA rating | 300 by DIN or 550 by BCI/SAE | |
| Sidepower fuse size: | ANL250 | |

Safety features on thruster (see seperate sheet for control panels):

- Forced shut-down by overheat sensor in motor
- All internal leads with extra insulation of webbed silicon increase resistance to heat and mechanical wear. Connectors have positive locking so that you have to pull by the insulator to release, can not be pulled off by the wires or loosen by themselves. Self extinguishing solenoid cover.
- IPC Standard electronic control box for protection against:
 - direct drive direction change
 - unique, patented protection of solenoid from extra wear and damages in low voltage situations for example caused by drained or damaged batteries as well as "auto-stop" without the need for the skipper to shut down the main switch immediately to stop the thruster in case of a solenoid lock-in **
 - auto-stop if control signal is continous for more than 3 minutes to protect against potential short circuit in control cables.

Notes !

* Actual performances, current consumption etc. will vary for each installation depending on many factors. Spesifications here given at one tunnel diameter depth and with voltage at thruster as shown. If you install deeper the thrust will be more as well as the current consumption, and the running time will be reduced. Electromotors power and afficiency tolerances are +/- 6%.

** New patented safety features in the thruster controlbox will be available in 2005 model year units.

SIDE-POWER

Thruster systems



Product Specifications SP 55 Si

Installation planning

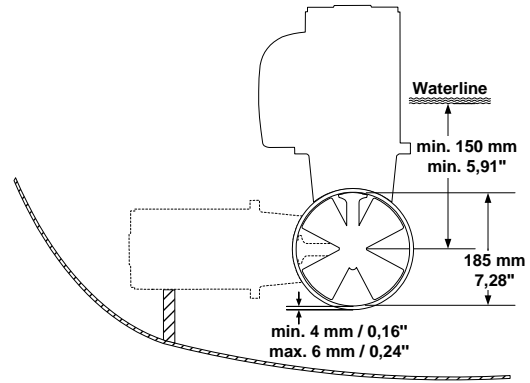
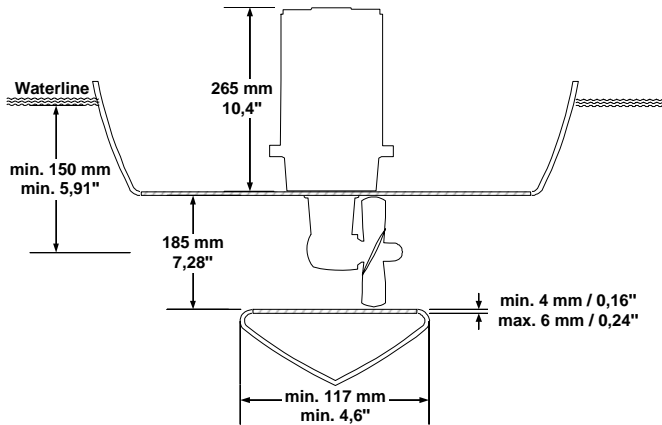

| Table for selection of main cable, battery, fuse and main-switch sizes. | | | up to 7m total + & - | | 8 - 11m total + & - | | 12 - 15m total + & - | | 16 - 19m total + & - | | 20 - 23m total + & - | | 24 - 27m total + & - | |
|---|---------|--------------|-----------------------------|-------------------------|-------------------------------|-------------------------|-------------------------------|-------------------------|-------------------------------|-------------------------|--------------------------------|-------------------------|------------------------------------|-------------------------|
| Model | Voltage | Current draw | Min. Cable dimension | Min. Battery CCA by DIN | Min. Cable dimension | Min. Battery CCA by Din | Min. Cable dimension | Min. Battery CCA by DIN | Min. Cable dimension | Min. Battery CCA by Din | Min. Cable dimension | Min. Battery CCA by DIN | Min. Cable dimension | Min. Battery CCA by Din |
| SP 55 Si | 12 V | 330 A | 35 mm ² AWG 1 | 350 CCA Din | 60 mm ² AWG 2/O | 350 CCA Din | 95 mm ² AWG 3/O | 350 CCA Din | 95 mm ² AWG 4/O | 400 CCA Din | 120 mm ² AWG 4/0 | 400 CCA Din | 120 mm ² 2 x AWG 3/0 | 400 CCA Din |
| | 24 V | 160 A | 25 mm ² AWG 4 | 200 CCA Din | 25 mm ² AWG 4 | 200 CCA Din | 35 mm ² AWG 2 | 200 CCA Din | 35 mm ² AWG 2 | 250 CCA Din | 50 mm ² AWG 1 | 200 CCA Din | 50 mm ² AWG 1 | 200 CCA Din |

Typical boat sizes:
SP55Si push the bow against a direct sidewind of approximately:

SeaRay 340 Sundancer - 21,7 knots.

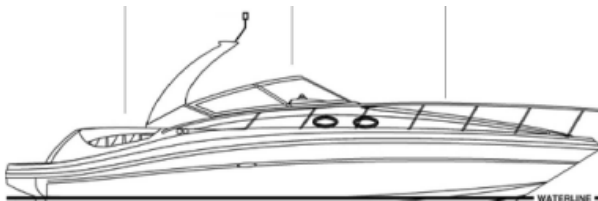

Fairline Targa 34 - 20,5 knots.



Bavaria 36 - 19,8 knots.

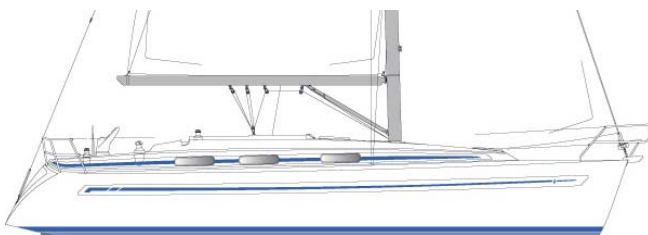

Mainship 30 Pilot - 22,6 knots.



Sleipner Motor AS
P.O. Box 519
N-1612 Fredrikstad
Norway

Tel: +47 69 30 00 60
Fax: +47 69 30 00 70

www.side-power.com
sidepower@sleipner.no

