

# SIDE-POWER

## Thruster systems

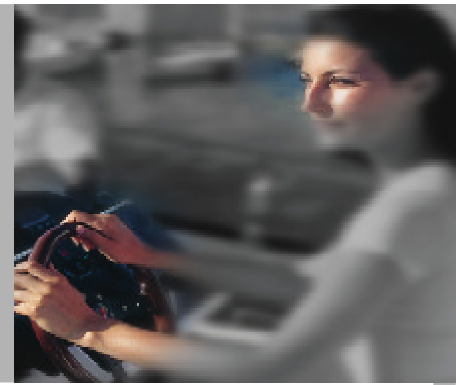

# SP 220 TC



### MAIN FEATURES

Thrust at 21 V	220 kg / 484 lbs.
Power	11,2 kW / 15 Hp
Tunnel diameter	300 mm / 11,8"
Propulsion system	Counter rotating
Voltage	24 V (12 V kit available)
Weight	70 kg / 154 lbs.
Boat size	60 - 84 foot
Current draw	nom. 670 A
Min. battery CCA DIN	700

This is probably the most powerful 24 V thruster on the market. The favourite thruster among leading boat builders for their high-end yachts.

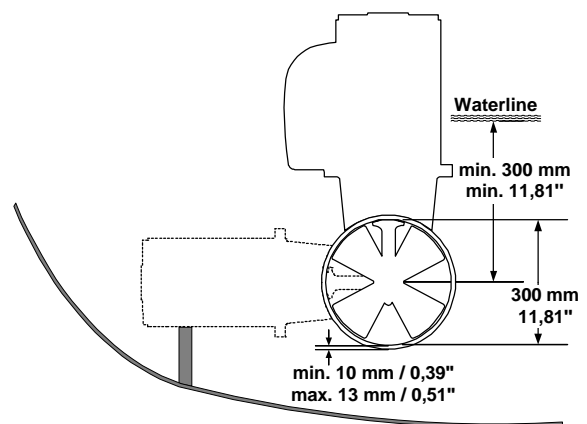
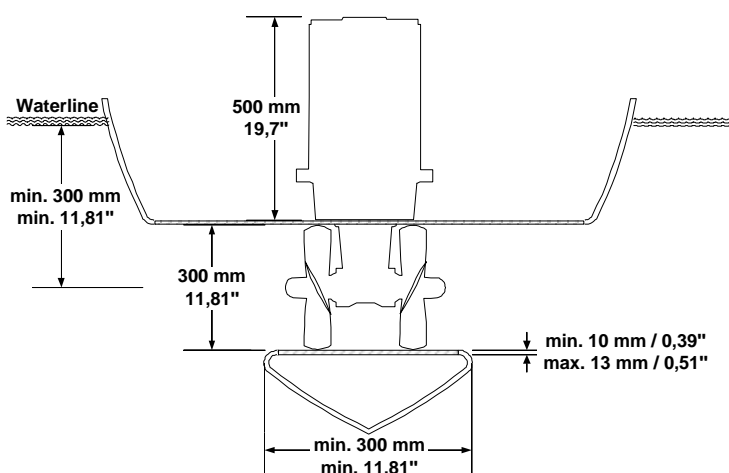

**Sleipner Motor AS**

P.O. Box 519  
N-1612 Fredrikstad  
Norway

Tel: +47 69 30 00 60  
Fax: +47 69 30 00 70

[www.side-power.com](http://www.side-power.com)  
[sidepower@sleipner.no](mailto:sidepower@sleipner.no)

