

# Product Specifications SR 170/250 TC



### Description:

Typical boat size	50 - 70 foot / 15 - 22m
Tunnel inside diameter	250 mm/9,8" (see back for more measurements)
Propulsion system	Twin Counter rotating
Available for DCsystem	24V (12V kit available)
Weight	88kg/194lbs.

### Specific Retracting thruster features:

- Plug and play S-Link two way communication control system
- Motor assembly rigid mounted on retract casing - no moving parts during retract operation, making critical cable connections very secure
- Compact measures
- Sturdy and reliable retract mechanism, avoids jamming
- Fast deployment time
- Easy to use control panel with status feedback from thruster
- Hatch deploys straight out of hull for minimal cutout gaps, creating minimal drag
- Compatible with the DC Speed Control system for full proportional control

### Gearleg:

- Seawater resistant bronze, CNC machined in one process to ensure 100% correct tolerances, angles and measurements.
- Sealed gearleg with long-life "mechanical" seal where polished ceramic and carbon surfaces form the only moving sealing surfaces, ensuring protection against damaging water intrusion into gear leg.
- Lifetime lubricated with special gear-oil.
- Hardened and ground precision spiro-conical gears.
- Propeller shaft with double ball bearings fitted in correct tolerances.
- Driveshaft with ball bearing and special sleeve bearing in correct tolerances.
- Connection between motor and driveshaft by flexible coupler
- 5 bladed composite "Q-prop" propeller, skewback design.
- Zinc anode protection directly on gearleg, easy to access and change.
- Gearleg galvanically insulated from bracket/motor

### Performance and specifications\*:

	At 21V	At 24V
Thrust	170kg/374lbs.	< 210kg/462lbs.
Output power	8kW/10,7 Hp	<8,8kW/11,8Hp
Average current draw	nom. 500A	<550A
Continuous run time (20°C)	3 min.	> 2,5 min.
Approx. long term run time	10% of time	7% of time
Min. battery CCA rating 24V	550 CCA DIN/1045 CCA SAE	
Sidepower fuse size:	ANL400	

### Safety features on thruster (see separate sheet for control panels):

- Forced shut-down by overheat sensor in motor
- All internal leads with extra insulation of webbed silicon increase resistance to heat and mechanical wear. Connectors have positive locking, so that you have to pull by the connectors to release. You cannot pull off by the wires and they will not loosen by themselves.
- S-link integrated IPC for protection against:
  - direct drive direction change
  - unique, patented protection of solenoid from extra wear and damages in low voltage situations for example caused by drained or damaged batteries as well as "auto-stop" without the need for the skipper to shut down the main switch immediately to stop the thruster in case of a solenoid lock-in\*\*

### Notes !

\* Actual performances, current consumption etc. will vary for each installation depending on many factors. Specifications here given at one tunnel diameter depth and with voltage at thruster as shown. If you install deeper the thrust will be more as well as the current consumption, and the running time will be reduced. Electromotors power and efficiency tolerances are +/- 6%.

\*\* Patented safety features in the thruster S-link controlbox.

Some boats do not have the possibility to fit a tunnel thruster and thereby require a retractable thruster. Side-Power now extends the range of series of retractable thrusters after having talked to the market and identified the weaknesses in existing solutions and improved these to offer retractable thrusters in true Side-Power spirit with no compromise on safety and reliability.

The retracting thrusters are built with the same high safety standards as all Side-Power products, and incorporate all features introduced with the SE-series thrusters. Our focus on safety is a totally integral part of the product design so that everything from build quality to ease of installation is thought of to ensure long term reliability.

The SR-series thrusters incorporate all the advanced features from the SE-series tunnel thrusters:

- Q-prop
- Sealed Drive - lifetime lubricated
- Galvanic Separation
- IPC intelligence for extra safety



Confidence by Control

SIDE-POWER.com

# PRODUCT SPECIFICATIONS

## SR 170/250 TC

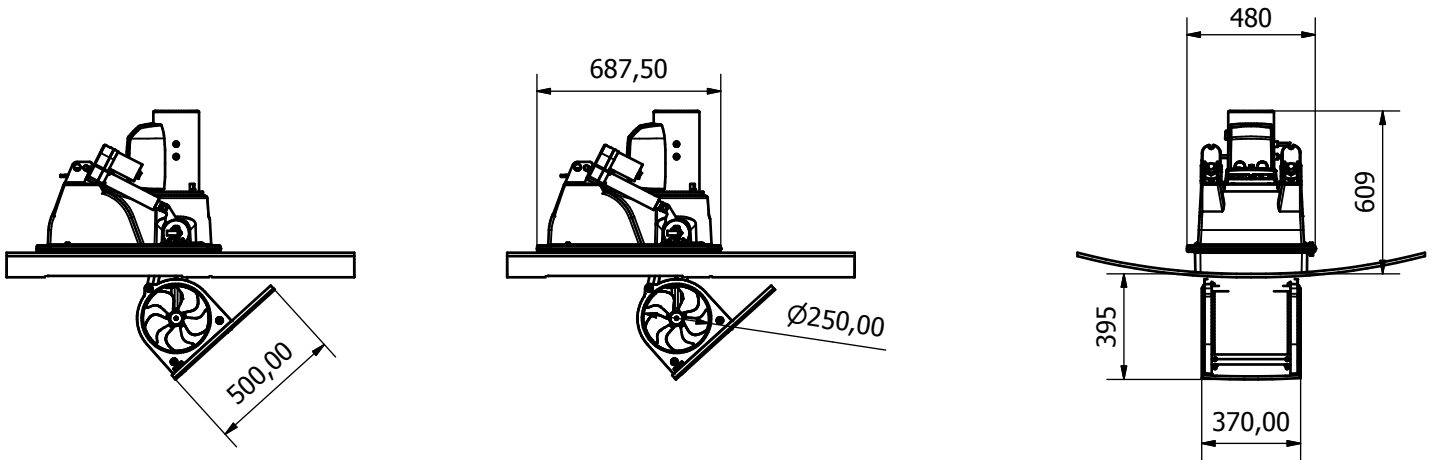

Battery & cable recommendations:

Table for selection of main cable, battery, fuse and main-switch sizes.				up to 7m total + and -		7 - 14m total + and -		14 - 21m total + and -		21 - 28m total + and -		28 - 35m total + and -		over 35m total + and -	
		Voltage	Amp. Draw	Min. Cable size	Min. Battery cold crank	Min. Cable size	Min. Battery cold crank	Min. Cable size	Min. Battery cold crank	Min. Cable size	Min. Battery cold crank	Min. Cable size	Min. Battery cold crank	Min. Cable size	Min. Battery cold crank
SR 170/250 TC	Direct to battery bank	24 V	480A to 540A	50 mm <sup>2</sup> O	500 CCA DIN 950 CCA SAE	70 mm <sup>2</sup> OO+	500 CCA DIN 950 CCA SAE	70 mm <sup>2</sup> OO+	550 CCA DIN 1045 CCA SAE	90 mm <sup>2</sup> OOO+	600 CCA DIN 1140 CCA SAE	100 mm <sup>2</sup> OOOO	600 CCA DIN 1140 CCA SAE	120 mm <sup>2</sup> OOOO+	600 CCA DIN 1140 CCA SAE
	Bow battery min. 250A 24V crank capacity*	24 V		N/A		N/A		N/A		50 mm <sup>2</sup> O	250 CCA DIN 475 CCA SAE	70 mm <sup>2</sup> OO+	300 CCA DIN 570 CCA SAE	70 mm <sup>2</sup> OO+	300 CCA DIN 570 CCA SAE

Minimum and recommended cable dimensions can be identical due to safety margins and cable heat considerations for short cable lengths.

\* Minimum or recommended cable cross section in mm<sup>2</sup>



### PJC 211/212 Single/Dual Proportional Control Panel

- Plug and play S-link control cable wiring (waterproof plugs)
- Finger tip control with purpose designed joysticks
- Hold - function for easy docking, runs thrusters at selected power (Dual panel only)
- Back-lit LCD display with instant feedback
  - Amount of thrust & direction of thrust
  - Thruster temperature/remaining run time
  - Battery status
- Selectable LCD colour & level for both night and day
- System monitoring simplifies troubleshooting
- in/out movement
- Interactive multilingual menus
- Built-in audible alarm "buzzer"



### PPC 800 Power Control Unit

- Plug and play S-link control cable wiring
- Easy to access, solid main cable terminals
- Easy to place as it can be located anywhere between the batteries and the thruster, also in areas requiring ignition protected parts
- Reliable solid state switching
- Thermal and over current protection
- Active cooling for continuous usage



### 8700 S-link On/Off control panel

- Bus-based two way communication system
- Thin cables with compact connectors
- Waterproof connectors
- Thruster status indicators
- Easy operation - activate panel and thruster deploys, shut off panel and thruster retracts.



This document may contain typographical errors, to which Sleipner Motor assumes no responsibility.



Confidence by Control  
**SIDE-POWER.com**

Product specification - SR 170/250 TC - 2/2



Sleipner Motor AS  
P.O. Box 519,  
N-1612 Fredrikstad, Norway  
Tel: +47 69 30 00 60  
Fax: +47 69 30 00 70  
sidepower@sleipner.no  
www.side-power.com